

WASTEQUIP

WASTEQUIP - 6030HD - Vertical Baler

6030HD Vertical Baler Wastequip's Most Popular Cardboard Baler

**Safety, high quality, and performance:
You get it all and a great price.**

Wastequip's 6030HD Baler is perfect for your cardboard baling needs. You get a powerful 10HP motor, quick 45 second cycle time, and built-in fork lift pockets. With a height under 8 feet it will fit under most doorways. The 27 1/2" feed opening is the largest in the industry for a 6030HD baler. Combine all that with an eye level side mounted power unit and you have the perfect baler for you, your operators, installers, and service technicians. The best part is you get a great price to go along with all the following standard features.



Standard Features	Advantages	Benefits
Built-in Fork Lift Pockets	Easy and Safer to Transport / Install	Others Charge \$400 for This Option
96" Transport and Install Height	Fits Vertically Under Most Doorways	Quicker Installation = Lower Cost
27 1/2" Feed Opening	Largest in the Industry	Large Cardboard Boxes Are Easy to Load
Eye Level Oil Sight and Temperature Gauge	Visible Indicator of Oil Volume, Cleanliness, and Temperature	Avoid Costly Repairs due to Oil Problems
UL Listed Solid State Electronic Controls	Easy to Program and Maintain	No Costly Moving Parts to Repair
NEMA 4 Control Panel	Protection against "Windblown Dust", "Splashing Water", and "Hose Directed Water"	Others Charge \$140 for This Option
Push / Pull Emergency Stop Button	Increases Operator Safety by Allowing Shut Down of Baler	Others Charge \$65 for This Option
10HP Motor	Eye Level Side Mounted Power Unit	Easily Accessible for Service or Maintenance
45 Second Cycle Time	One of the Fastest in the Industry	Allows Your Employees to Return to Work Faster
Ejection Plate	More Robust than Ejection Chains	Others Charge Extra for This Feature
Safety Cable thru Cylinder	Protects in The Event of Cylinder Pin Failure	Others Charge \$207 for This Feature
Front and Rear Retaining Teeth	Stabilizes Bale and Increases Density	Heavier Bales
Low Temperature Oil	High Performance HD32 Hydraulic Oil	Wider Temperature Operating Range
Outdoor Protective Paint Finish	High Quality Paint Finish	Long Lasting Protection Against Oxidation and a Rust Inhibitor

6030HD Vertical Baler

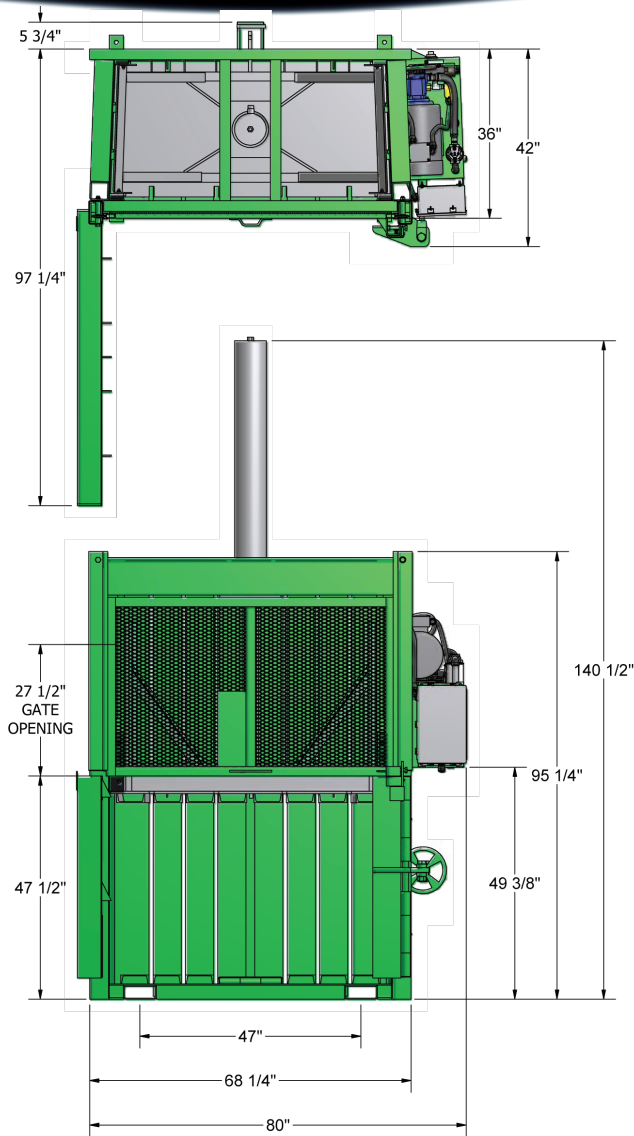

MODEL 6030HD	
CYLINDER BORE	6"
CYLINDER ROD	3.5"
CYLINDER STROKE	48"
MOTOR HP	10
PHASE & VOLTAGE	3 PHASE 208-230/460
BALE WEIGHT OCC	800-1000#
BALE SIZE	60" X 30" X 48"
FEED GATE OPENING	27 1/2" X 60"
FEED HEIGHT	47 1/2"
PLATEN AREA (sq. inches)	1800
PLATEN FORCE (lbs.)	62172
OPERATING PRESSURE	2200 PSI
CYCLE TIME (sec.)	45
CONTROL VOLTAGE	110 V
PUMP SIZE GPM @ 1850 RPM	13
SHIPPING WEIGHT (lbs.)	4100

*Optional Features: Bale Wire Guides, Oil Heater, and Full Bale Light

Features of the 6030HD Baler



Baler being loaded on a standard flatbed by a fork lift.



Built-in fork lift pocket for ease of transport and installation of baler.



Phone: 877-468-9278
Fax: 651-437-2272
Email: sales@wastequip.com
www.wastequip.com

Wastequip serves North America from nationwide locations with quality; containers, roll-off hoists, self-dumping hoppers, compactors, balers, trailers and tarps for companies in environmental preservation and material handling.

May 2009 © Wastequip, all rights reserved. Specifications subject to improvement without notice. Equipment displayed should be operated by properly trained personnel. Operators should become familiar with OSHA, ANSI and any other applicable standards or laws for using this equipment. Improper use, misuse, or lack of maintenance could cause injury to people and/or property. Photos used in the literature are illustrative only. We assume no liability or responsibility for proper training/operation of equipment not manufactured by Wastequip. We reserve the right to make changes at any time without notice. Information contained within this literature is intended to be the most accurate available at time of printing.