



WASTEQUIP

APARTMENT COMPACTOR C-33X-APT



Compactor (with hopper door)
allows side feed, rear feed or chute feed.
Shown with compaction container.

Compaction is the key to savings

Specifically designed to fit into tight trash rooms of high-rise complexes and apartment buildings where space is a commodity. The C-33X-APT apartment compactor features a crossed scissor cylinder mini design and totally automatic operation to eliminate waste generated by all floors of a building. Typically used in cooperation with chute feed applications, this mighty compactor also offers a ground loading access

door and standard single side attachment to the receiving container. The Wastequip apartment compactor will certainly minimize the overall cost, pick up frequency, and number of labor hours associated with standard containers, thereby making it the smartest choice for any structure where a common waste area is utilized.

Compactor general specifications

Wastequip rating .33 cu yds	Charge box width 29.75"
Wastec rating .23 cu yds	Charge box length 22.00"
Height-67"	Weight with power unit – 1,480 lbs
Length-44 1/4"	
Width-38 1/2"	

Ram performance and specifications

Height-16.75"	Normal packing force-14,350 lbs
Ram penetration-6.00"	Normal packing pressure-1700 psi
Face plate-1/2"	Normal ram face pressure-28.8 psi
Base-3/8" plate	Maximum packing force-16,880 lbs
Top-3/8" plate	Maximum packing pressure-2000 psi
Sides-1/4" steel	Maximum ram face pressure-33.9 psi

Packer specifications

Floor plate-3/8"
Steel sides-1/4" with 4" reinforcing channel stiffeners
Top rail-1/4", formed steel cross member adds stiffness
Bottom rail-1/4" formed channel cross member for stiffness
Breaker bar-4 x 4 x 1/2" angle steel
Top deck cover-formed 1/4" steel for strength (cover is standard)

Electrical specifications

Electric motor-5 HP	Housing type-TEFC
Motor RPM-1800	Control circuit-24V
Voltage-208/230/460, 3 phase, 60 HZ.	Control panel-UL Rated
Option - 575 volts	

Hydraulic specifications

Pump-5.00 gpm	Cycle time-18 seconds
Cylinders-two in scissor style,	Cu Yds per hr-46
Cross alignment	Tank-10 gallons
Cylinder bore-2.50"	Power unit location-remote
Cylinder rod-1.375"	
Cylinder stroke-20.00"	

Operation

Automatic Cycle Operation. Unit works in cooperation with photo electric eye, retracts and stops automatically as necessary to clear hopper. Full container light is included on panel.

Parts

Wastequip offers replacements parts and add-on features for this and other waste machines.

Colors

We offer several standard colors, ask our representative for choices.

WASTEQUIP - APARTMENT COMPACTOR C-33X-APT

APARTMENT COMPACTOR C-33X-APT

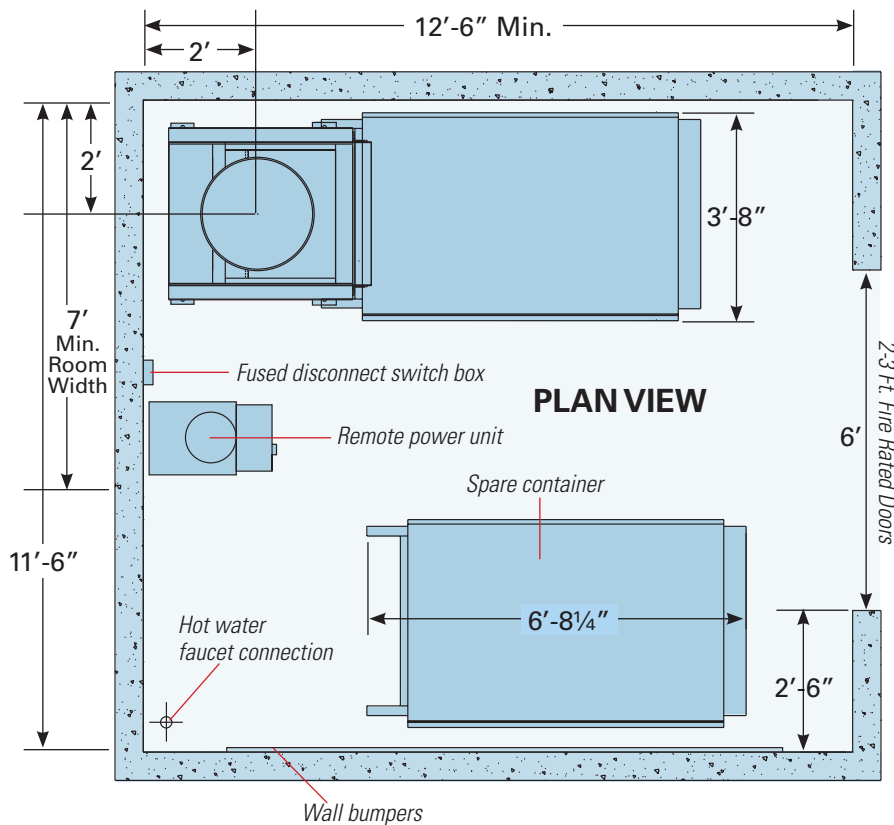
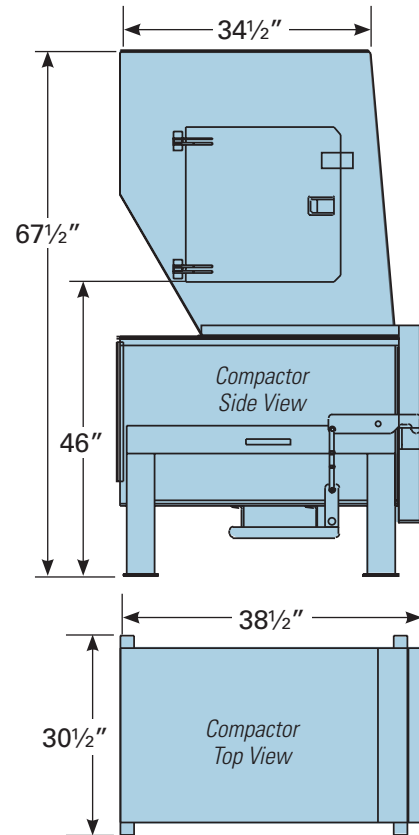
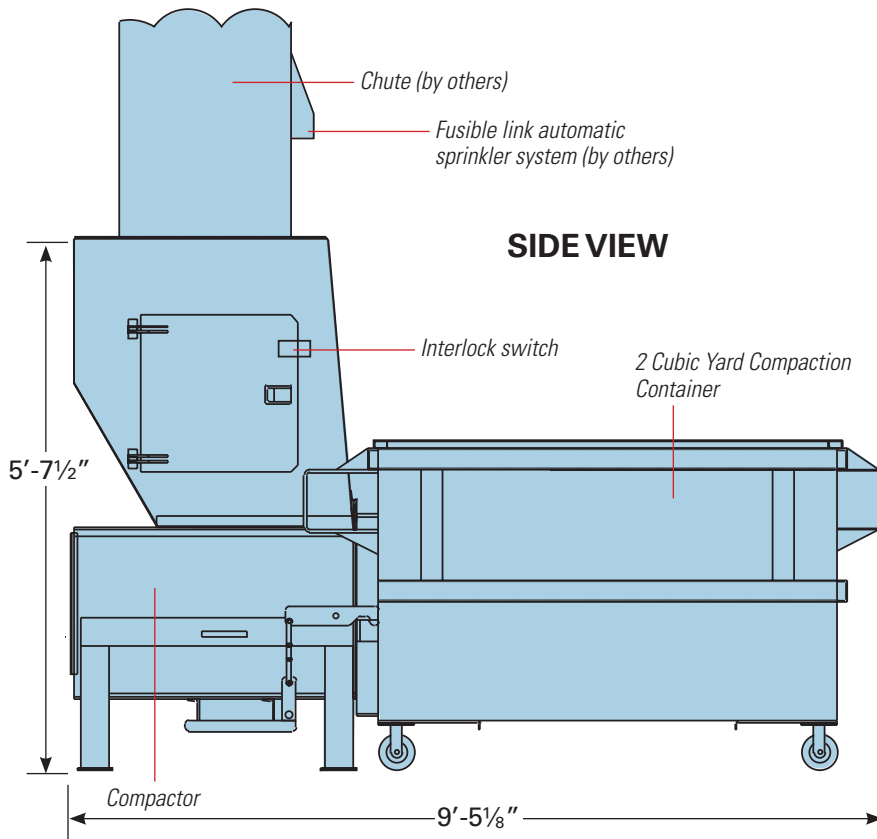

WASTEQUIP
Nationally known for personal service

Phone 877-468-9278
Email: sales@wastequip.com
www.wastequip.com

Dec 2007, Version B, ©2007 Wastequip, all rights reserved. Specifications are subject to change without notice.

Caution
This equipment should be operated by properly trained personnel. Operators should become familiar with OSHA, ANSI and any other applicable standards or laws for using this equipment. Improper use, misuse, or lack of maintenance could cause injury to people and/or property. Photos used in the literature are illustrative only. We assume no liability or responsibility for proper training/operation of equipment not manufactured by Wastequip. We reserve the right to make changes at any time without notice. Information contained within this literature is intended to be the most accurate available at time of printing.