



WASTEQUIP

VERTICAL BALERS

WASTEQUIP - VERTICAL BALERS

Vertical balers by Wastequip can help turn recyclables into revenue

Vertical balers are designed to work in areas with limited space for the recycling of cardboard, paper or plastic. Heavy-duty rugged construction guarantees reliability and years of service. We offer many models and sizes to meet your requirements.

Features

- Cardboard retainer teeth - front
- Tri Volt energy efficient 10HP TEFC motor
- 10" wheel door lock ratchet
- NEMA 4 - Weatherproof control panel

Options

- Automatic bale ejector hookup and release
- Hinged retainer teeth
- Single phase motor
- Automatic wire guides
- Fork lift pockets



Vertical Baler Specifications

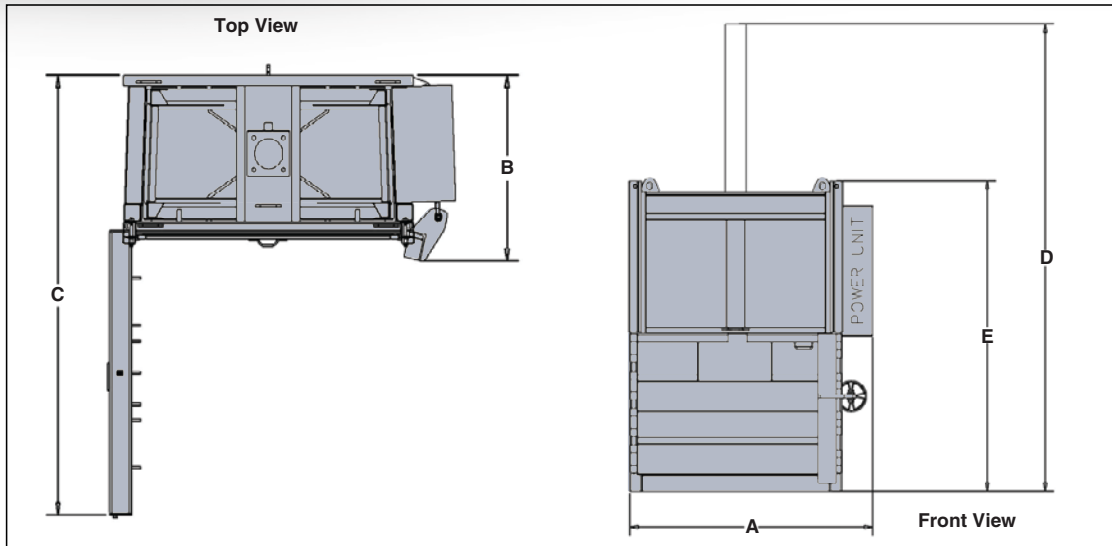

DIMENSIONS

MODEL	3624HD	4824W	4830HD	6030HD	6030XHD	6030XXHD	7230HD	6030HD LO-PROFILE	4054HD	4054XHD
"A" WIDTH	57"	69"	69"	81"	81"	81"	93"	81"	75"	75"
"B" DEPTH	38"	41"	44"	44"	44"	44"	44"	44"	54"	54"
"C"Depth + door open clearance	74"	87"	92"	104"	104"	104"	116"	104"	108"	108"
"D" Height w/cylinder	95"	119"	143.5"	143.5"	143.5"	168"	143.5"	118"	143.5"	143.5"
"E"Height wo/cylinder	79"	87"	100-3/4"	100-3/4"	100-3/4"	100-3/4"	100-3/4"	93"	100-3/4"	100-3/4"

GENERAL SPECIFICATIONS

MODEL	3624HD	4824W	4830HD	6030HD	6030XHD	6030XXHD	7230HD	6030HD LO-PROFILE	4054HD	4054XHD
CYLINDER BORE	3-1/2"	4-1/2"	6"	6"	6"	7"	6"	6"	6"	6"
CYLINDER ROD	2"	3"	3.5"	3.5"	3.5"	5"	3.5"	4"	3.5"	3.5"
CYLINDER STROKE	30"	36"	48"	48"	48"	69"	48"	31"	48"	48"
MOTOR HP (5-15)	5	10	10	10	10	15	10	10	10	10
PHASE & VOLTAGE	3 PHASE 208-230/460	3 PHASE 208-230/460	3 PHASE 208-230/460	3 PHASE 208-230/460	3 PHASE 208-230/460	3 PHASE 208-230/460	3 PHASE 208-230/460	3 PHASE 208-230/460	3 PHASE 208-230/460	3 PHASE 208-230/460
BALE WEIGHT OCC	250 - 460#	350 - 550#	650-800#	800-1000#	900-1200#	1100-1400#	900- 1100#	750-950#	900-1100#	900-1200#
BALE SIZE	24"X 36"X36"	24"X 48"X36"	30"X 48"X43"	30"X 60"X48"	30"X 60"X48"	30"X 60"X48"	30"X 72"X48"	30"X 60"X48"	40"X 54"X48"	40"X 54"X48"
FEED GATE OPENING	18" X 36"	24" X 48"	26" X 48"	26" X 60"	26" X 60"	26" X 60"	26" X 72"	20" X 60"	26" X 54"	26" X 54"
FEED HEIGHT	37"	43"	50-1/2"	50-1/2"	50-1/2"	50-1/2"	50-1/2"	50-1/2"	50-1/2"	50-1/2"
PLATEN AREA (sq inches)	864	1116	1440	1800	1800	1800	2160	1800	2160	2160
PLATEN FORCE (lbs.)	21156	29408	62172	62172	64998	88470	62172	62172	62172	64998
OPERATING PRESSURE	2200 PSI	1850 PSI	2200 PSI	2200 PSI	2300 PSI	2300 PSI	2200 PSI	2200 PSI	2200 PSI	2300 PSI
CYCLE TIME (sec)	30	40	45	45	45	64	45	40	45	45
CONTROL VOLTAGE	110V	110V	110V	110V	110V	110V	110V	110V	110V	110V
PUMP SIZE GPM @1850 RPM	4.5	6	13	13	13	13	16	13	13	13
SHIPPING WEIGHT (lbs.)	2771	3600	3950	4500	4940	5740	5080	4480	4860	4950



WASTEQUIP
Nationally known for personal service

Phone 877-468-9278
Email-sales@wastequip.com
www.wastequip.com

Wastequip serves North America from over 30 locations with quality; containers, roll off hoists, self-dumping hoppers, compactors, balers, trailers and tarps for companies in environmental preservation and material handling

April © 2008 Wastequip, all rights reserved. Specifications subject to improvement without notice. Equipment displayed should be operated by properly trained personnel. Operators should become familiar with OSHA, ANSI and any other applicable standards or laws for using this equipment. Improper use, misuse, or lack of maintenance could cause injury to people and/or property. Photos used in the literature are illustrative only. We assume no liability or responsibility for proper training/operation of equipment not manufactured by Wastequip. We reserve the right to make changes at any time without notice. Information contained within this literature is intended to be the most accurate available at time of printing.